

STUDY AND COMPARISON BETWEEN HARMONICS GENERATED IN STEEL INDUSTRY

Y .DJEGHADER¹, H.LABAR ², Z.CHELLI¹, R.TOUFOUTI¹

¹ Department of Electrical Engineering, University of Mohamed-Cherif Messaadia ,Souk Ahras, ALGERIA .

E-mail : djeghaderyacine@yahoo.fr , and yacine.djeghader@univ-soukahras.dz

¹LEER Laboratory University of Mohamed-Cherif Messaadia ,Souk Ahras, ALGERIA;

²Department of Electrical Engineering, University of Badji Mokhtar ,Annaba, ALGERIA.

Abstract_ *In Steel Industry a DC electric arc furnace (DC EAF) is an important nonlinear time-varying load in power system. The operation of DC EAF causes many power quality problems especially they generate currents harmonics. In this paper we present a model of DC Electric Arc Furnace based on the stochastic nature of the electric arc current-voltage characteristic. For the study of harmonics generated in this steel industry with different structures proposed basing on utilization of twelve power rectifiers. The model has been implemented using a numerical simulation environment to facilitate later analysis. Finally, the simulation results are compared with different structures of a DC EAF, when the total Harmonic Distortion (THD) is determined and spectral representation to compares between each structure.*

Keywords_ *Electrical arc, DC EAF, Modelling, Harmonics, Power Quality, Simulation*

1. Introduction

The quality of power supply is very important nowadays. The dc arc furnaces, among others, generate a wide spectrum of harmonics, which deteriorate the quality of the delivered energy, increases the energy losses and decreases the reliability of a power system [1, 2]. The precise control of chemistry and temperature encouraged use of electric arc furnaces during World War II for production of steel for shell casings [2]. Today steelmaking arc furnaces produce many grades of steel, from concrete reinforcing bars and common merchant-quality standard channels, bars, and flats to special bar quality grades used for the automotive and oil industry. DC Arc furnace is the most versatile means for melting ferrous metals. Until recently, AC Arc Furnaces were used for melting as generation & distribution of AC power was convenient. But with the progress in thyristors Technology, DC Supply has become a genuine alternative to AC Supply [5, 6].

2. Furnace operation

The electric arc furnace operates as a batch melting process producing batches of molten: steel known "heats". The typical EAF load cycle varies from 4 to 7 hours depending upon the size of the furnace and metallurgical requirement .The operation of the arc furnace is divided into melting and refining stages [4, 7]. The random property of arc melting process contributes to lowering of power factor resulting in additional voltage drop through the power system yielding a lower system voltage on the plant buses. The arc melting process is a very complicated process. It converts the electrical energy into thermal energy. The electric arc is used to melt the raw materials held by the furnace. The random movement of the melting material results in heavy current fluctuations during the arc melting process. During the refining period, the scrap metal is at a molten form and hence fluctuations are small Modern operations aim for a tap-to-tap time of less than 60 minutes. Some twin shell furnace operations are achieving tap-to-tap times of 35 to 40 minutes [7, 8].

3. Advantage of DC. Arc Furnace

DC mode of operation ensures high arc stability, eliminates inrush currents and disturbances in Power System [3].

- Reduce metal loss by 2 - 4 -5 %.
- Reduces electrode consumption by 60%.
- Lower energy consumption by 5 - 7%.
- Absence of Hot Spots and Lower refractory consumption by 20%.
- DC flicker is 20% of AC flickers as current control reduces fluctuation of reactive power, Can also work on weak lines.

- Homogeneous temperature & composition due to intense stirring in molten metal.
- Ability to melt high percentage of DRI in the charge.
- Fewer mechanical components with less wear & tear reduce maintenance costs to only 40%.
- Environment friendly system with lower dust load by 80% & hence lower cost of pollution control equipment by 50%.
- UNIARC does not require Static VA Compensators for operation.

4. MODEL description

Our EAF melt steel, is applying by a DC current to load steel scrap by means of graphite electrodes. Compose essentially a 225/63 kV step-down transformer, and a second three wind transformer, one is coupled star and the other in a triangle, feeds a twelve pulse rectifier as shown in the following figure.

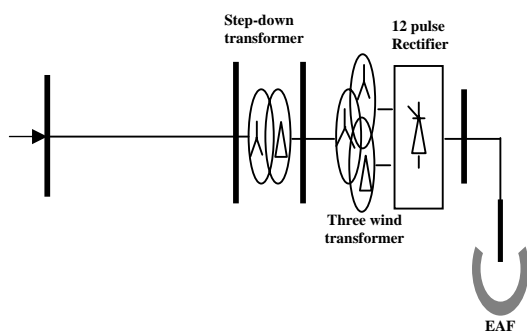

Fig1. Modelled dc arc furnace plant

The opportunities of the DC EAF simulator is mainly based on the release of twelve pulse rectifier (i.e. the number of electrodes used 1, 2,3), as well as the use of neutral connection. A typical DC arc furnace plant, is modelled as it is shown in Figure 1.

4.1. Twelve pulse rectifier

The principle consists in using a transformer with two secondary delivering voltage delayed of 30° between them, each of these secondary supply a rectifier in bridge of Graetz that achieves a 12 pulses DC current [9].

So this structure regroups two converters. A bridge with a Y Y connection (PD3), and another bridge Y Δ connection (S3).

The rectifiers must provide identical continuous currents so that the alternating currents in the secondary of the transformers take the same values.

In these conditions, there is a recombination of the harmonic currents, generated by each of the

rectifiers to the primary of the transformer and the calculation shows that the harmonic of rang $6k \pm 1$ are eliminated.

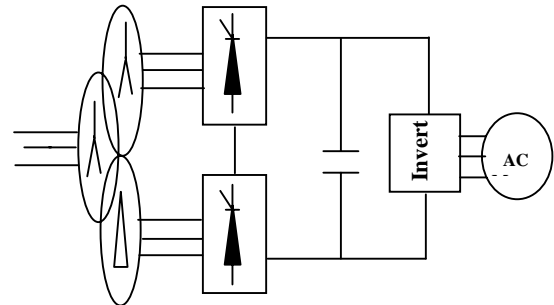

Fig 2. Twelve pulse rectifier

The first is three phase to a connection star / star, therefore its current profile is represented as follows.

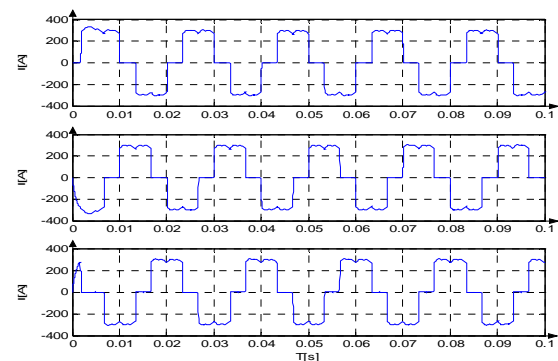

Fig 3. Current at the star of transformer rectifier

The second is three phase set to a connection star / triangle, therefore its current profile is represented as follows.

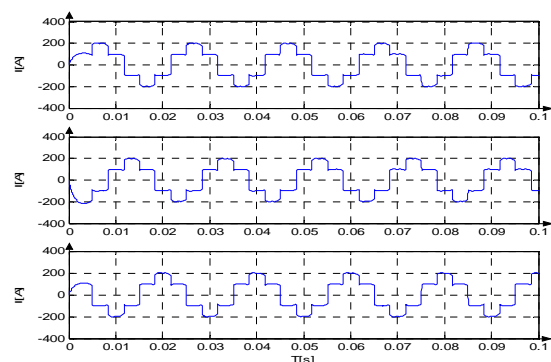

Fig 4. Current at the triangle of transformer rectifier

The recombination of the two rectifiers' gives a bigger current with fewer harmonic (harmonic 5 and 7 are nil) and its current shape is as follows.

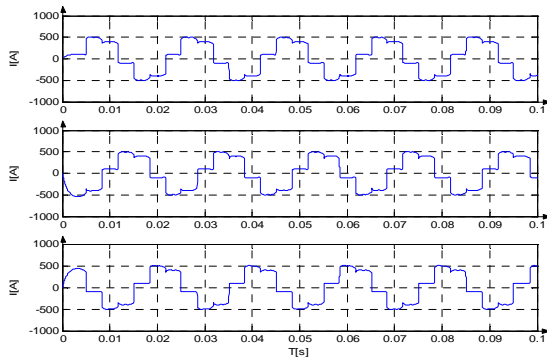

Fig 5. Current of twelve pulse rectifier

4.2. Model of arc furnace

According to the results of convenient measure we can draw the variation of the resistance and the reactance of the bow according to the distance between the electrodes and scrap as shown on the following figures (6a and 6b).

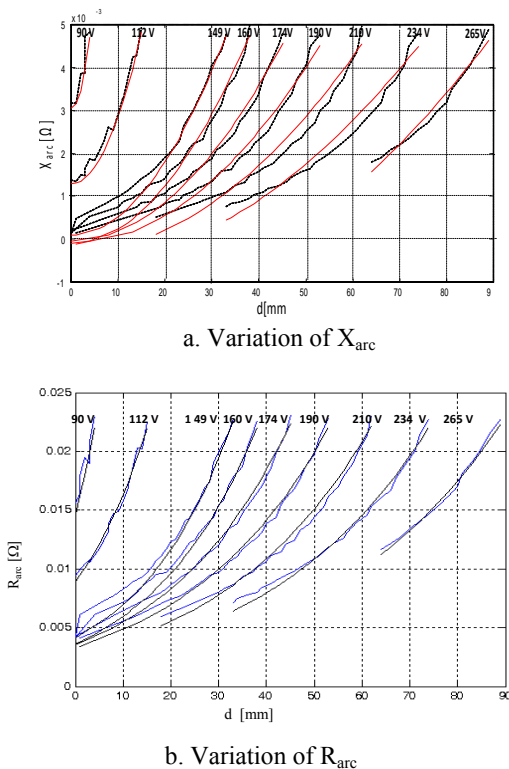

Fig 6. Variation of electric arc impedance.

Following to the treatment an empirical model is proposed [13]:

$$R_{arc} = A_R(u) e^{\alpha(u)d} \quad (1)$$

Where

$$A_R = \frac{[0,7.(U - 210)^2 + 1,7]}{50^2} \cdot 10^{-3} \quad (2)$$

$$\alpha = 0,097 e^{0,011(90-U)} - \frac{1,7}{(U - 112)^2 + 80} + \frac{100}{(U - 360)^2 + 50} \quad (3)$$

$$X_{arc} = A_X(u)d^2 + B_X(u) \quad (4)$$

Where

$$A_X = 1,05 \cdot 10^{-3} e^{0,075(90-U)} \quad (5)$$

$$B_X = \frac{3,14}{153} - 3 \cdot 10^{-3} e^{0,075(90-U)} \quad (6)$$

d - Is the distance between electrode and scrap.

C. Different Proposed Structure

We propose four structures of a DC EAF as shown on the following figures:

Structure N°01:

We use three electrodes figure 7.

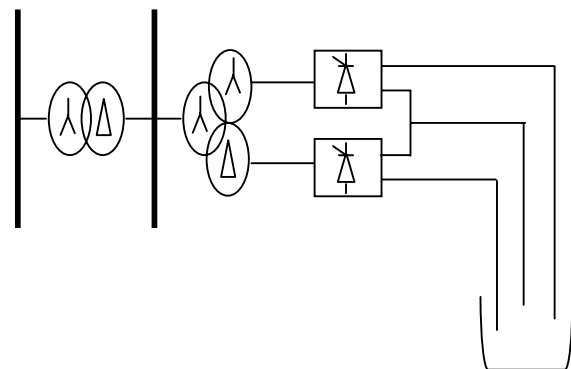

Fig. 7 Structure 01 of a DC EAF

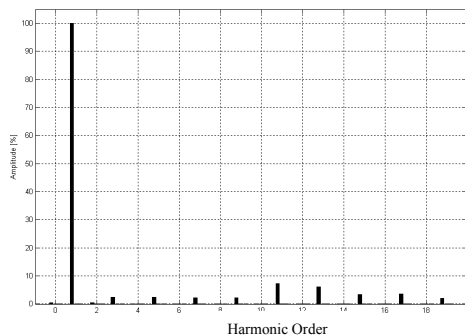

Fig 8. Harmonic Spectre of structure 01.

Structure N°02:

We use two electrodes (figure .9).

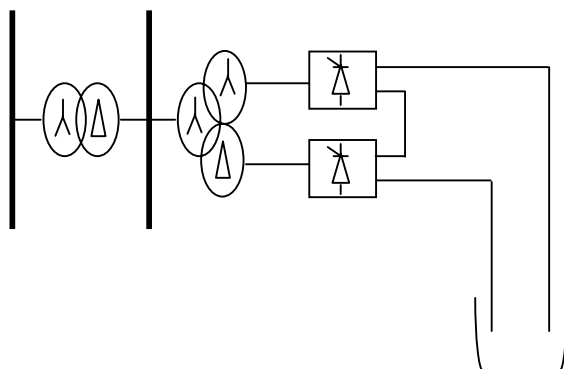

Fig 9. Structure 02 of a DC EAF

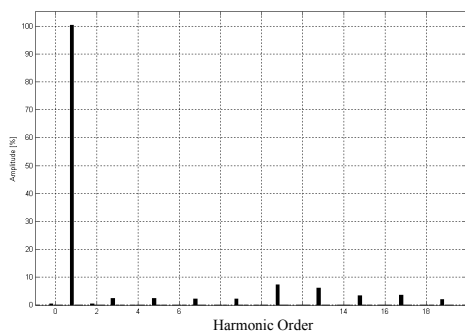

Fig 10. Harmonic Spectre of structure 02.

Structure N°03:

We use two electrodes with a neutral loop as shown on the figure.11.

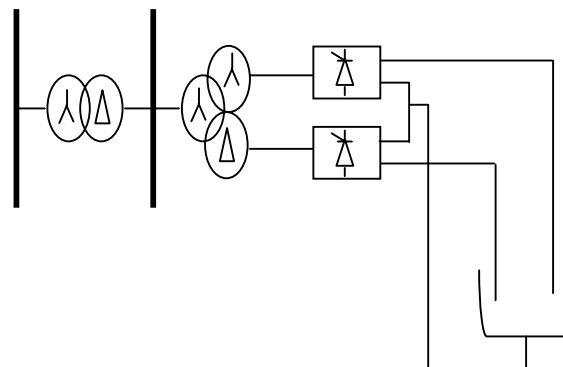

Fig 11. Structure 03 of a DC EAF

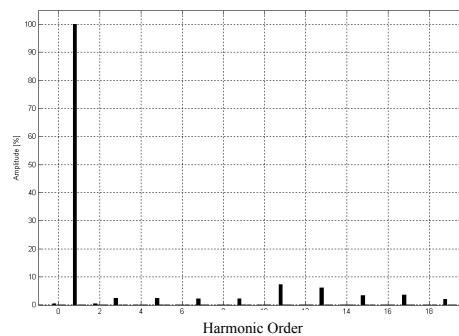

Fig 12. Harmonic Spectre of structure 03.

Structure N°04:

We use only one electrode with neutral loop as shown on the figure 13.

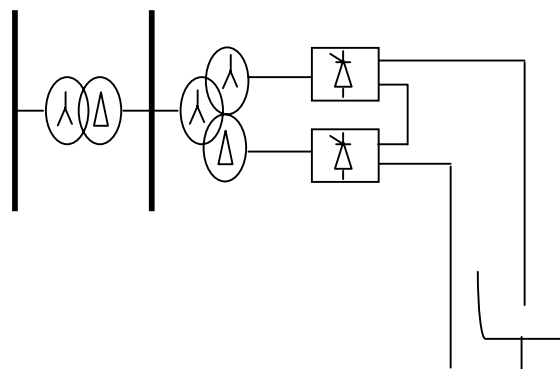

Figure 13. Structure 04 of a DC EAF

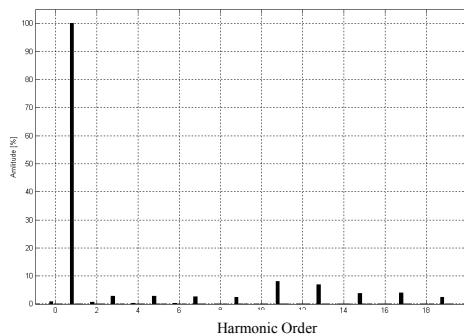

Fig 13. Harmonic Spectre of structure 04.

In these table we represent the values of the THD correspond to the different proposed structures

Table 1: Values of THD

Structure	THD _i (%)
Structure N°01	12.03
Structure N°02	12.01
Structure N°03	12.07
Structure N°04	13.44

5. Harmonic analysis

We know that with the use of twelve pulse rectifiers the existing harmonics are characterised by following relationship: $12k \pm 1$. But experience and analysis of the results also highlight a number of non-harmonic characteristics, amplitude non-negligible, especially in the area of low frequencies (harmonics ranges from 2 to 10) [9, 12].

Our analysis based on the speed of the current spread in the electric network and determine their total harmonic distortion, and their harmonic spectrum which shows the dominant harmonics that are in this flow, and according to these criteria we make a comparison between proposed structures and draws the best that provides a good quality of energy characterized by a low THD.

6. Conclusion

This paper presents a new DC Electric Arc Furnace model which implanted under numerical environment. In this work we have describe four proposed structures based in utilization of number of motoring electrodes and fixed one, So the simulation results according to this new models are shown, and compared.

According to the results of the simulation we pull the following findings.

- The harmonic 11 and 13 always exist and in the different structures with important magnitudes.
- The proposition N°02 is the best between the proposed structures, since its minimum THD
- The structure with only one electrode is the worst case.
- The three phase structure generates important low-frequency harmonics.
- The choice of each structure is based on the harmonics values under the achieved power quality.

To optimize the working of the DC EAF and to eliminate the harmonic it is sufficient to install two filters tuned to the ranks 11 and 13.

References

- [1] G. Carpinelli, F. Iacovone, A. Russo and P.Varilone, "Chaos-based modeling of DC arc furnaces for power quality issues," in IEEE Transactions on Power Delivery, Vol. 19, No. 4, October 2004, pp. 1869-1876.
- [2] B.Boulet, G.Lalli and M.Ajersch "Modeling and Control of an Electric Arc Furnace", Proceedings of the American Control Conference Denver, Colorado June 4-6, 2003, pp3060-3064.
- [3]G. Carpinelli, F. Iacovone, A. Russo, P. Verde and D. Zaninelli, "DC Arc Furnaces: Comparison of Arc Models to Evaluate Waveform Distortions and Voltage Fluctuations", Proc. 2001 IEEE PES 33th Annual North American Power Symposium (NAPS), College Station (Texas), 2001, pp. 574-580.
- [4] Sarshar A., Sharp M., "Analysis of harmonic and transient phenomena due to operation of an arc furnace", Iron & steel engineer, Assoc. iron & steel Eng. USA, April, 1996. vol. 73, no. 4, pp 78-82.
- [5] K. Timm, "Electric principles of DC-furnaces," Electrical Engineering of Arc Furnaces Symposium, Kehl, Germany, April 2005 18-21.
- [6]A. Bracale, G. Carpinelli, Z. Leonowicz, T. Lobos, J. Rezmer. "Waveform Distortions due to AC/DC Converters Feeding Dc Arc Furnaces", Trans. of EPQU 05 Conference, Cracow, Poland, 2005, submitted
- [7] P.Doulai "The impact of electric arc furnace operation on power quality of electric supply" In Proceedings of the International Power Engineering Conference (IPEC99), Singapore, May 1999, pp 751-756.
- [8] E.A. Cano Plata, H.E. Tacca, "Arc furnace modelling in ATP-EMTP," International Conference on Power Systems Transients IPST'05, Montréal, Canada, 2005.
- [9] Y.Djehader, H .Labar "Study and Filtering of Harmonics in Steel Industry", Acta Electrotechnica, Volume 53, N° 4, 2012; pp 272-277.

- [10] H. Schau, D. Stade, “*Mathematical modeling of three-phase arc furnaces*”. In Proceedings of the IEEE-ICHPS II, Bologna, September 1994, pp 422-428..
- [11] Tongxin Zhang, Elham B. Makram, “*An Adaptive Arc Furnace Model,*” IEEE Trans. Power Delivery, Vol. 15, pp. 931-939, July 2000.
- [12] D. Stade, H. Schan and S. Kramer, “*Modelling of the electrical behaviour of arc furnace,*” in Proc. 29th Universities Power Engineering Conference, Vol.1, 1994, pp. 125-128.
- [13] Y.Djeghader, H .Labar and K.Bounaya “*Modelling and Parametrical Approximation of an Electric arc Furnace Steelmaking*” Journal of Electrical Engineering (JEE) Vol. 9, N° 3, 2009, pp. 25-30.