

Efficient MPPT scheme for a photovoltaic generator using neural network

Farid Berrezzek
Fac. Sci & Tec., LEER Lab.
Univ. MCM of Souk Ahras
Souk Ahras, Algeria
 f.berrezzek@univ-soukahras.dz

Khaled Khelil
Fac. Sci & Tec., LEER Lab.
Univ. MCM of Souk Ahras
Souk Ahras, Algeria
 khaled.khelil@univ-soukahras.dz

Tahar Bouadjila
Fac. Sci & Tec., LEER Lab.
Univ. MCM of Souk Ahras
Souk Ahras, Algeria
 bouadjilaeln@gmail.com

Abstract—Maximum power point tracking (MPPT) is a widely used technique to achieve an efficient photovoltaic system in unstable climatic conditions of solar irradiation and temperature. This paper examines the issue of improving the efficiency of a photovoltaic generator (GPV) using an artificial neural network (ANN) based MPPT scheme. Generally, PV modules exhibit nonlinear $I-V$ characteristics with different MPPs depending on the solar irradiation and temperature. To ensure a maximum power transfer to the load from the GPV, it has to operate at its MPP. This is accomplished through matching impedance between the PV panel and the load using a DC-DC boost converter whose duty cycle is adjusted by artificial neural networks. With respect to the well known perturb and observe (P&O) MPPT, the obtained simulation results show that the considered ANN based approach is more efficient and oscillations around the MPP are significantly reduced.

Keywords— GPV systems, DC-DC boost converter, perturb and observe, ANN based MPPT.

I. INTRODUCTION

In recent years, PV technology has received considerable attention because of its environmental and economic benefits. In a PV power generation system, due to the high cost of the PV modules and their low conversion efficiency, the exploitation of the available power should be efficiently optimized. This performance optimization of PV generators, using power conversion systems, is usually known as Maximum Power Point Tracking (MPPT) [1]. Usually, MPPT utilizes a matching impedance DC-DC converter to extract the maximum possible power from the PV panel by continuously tuning the control signal duty cycle [1]. Over the last few decades, numerous MPPT control algorithms have been proposed. These MPPT methods vary in many aspects, including sensors employed, hardware implementation, cost, etc. Among them the Incremental Conductance (InC) [2], and the perturb and observe (P&O) which is, practically, the most widely used method because it can be easily implemented, good performance and low cost [3, 4]. However, this P&O MPPT technique shows oscillations in the vicinity of the MPP giving rise to waste of available power and system performance. Moreover, in rapid changing atmospheric conditions, namely solar irradiation, such classical MPP tracking methods may fail. To overcome these drawbacks, several intelligent MPPT approaches have been proposed,

including ANN and fuzzy logic controllers [5, 6]. In this paper a MPPT controller based on neural networks, for a standalone PV system, is presented. Employed with a DC-DC boost converter, the controller, compared to the P&O MPPT technique, exhibits good efficiency and better performance as it can rapidly and accurately track the MPP without, relatively, any power loss. Section 2 presents the architecture of the employed photovoltaic system along with the PV single diode model, the boost converter and the used artificial neural network (ANN). The results and discussions are given in Section 3. Section 4 concludes the paper.

II. SYSTEM DESCRIPTION

The considered photovoltaic system, shown in Figure 2, uses the KYOCERA KC200GT PV module whose electrical characteristics are reported in Table 1. The system employs also a DC-DC boost converter, a neural network based MPPT controller and a resistive load.

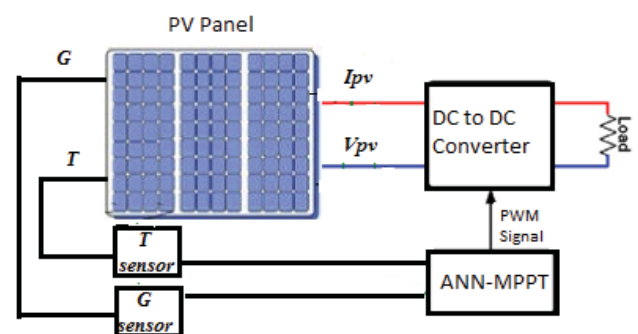

Fig. 1. Architecture of the used PV system

TABLE I: ELECTRICAL CHARACTERISTICS OF KYOCERA KC200GT

Maximum Power (Pmax)	200W (+10% / -5%)
Maximum Power Voltage (Vmpp)	26.3V
Maximum Power Current (Impp)	7.61A
Open Circuit Voltage (Voc)	32.9V
Short Circuit Current (Isc)	8.21A
Max System Voltage	600V
Temperature Coefficient of Voc	-1.23×10 ⁻¹ V/°C
Temperature Coefficient of Isc	3.18×10 ⁻³ A/°C

A. Mathematical model of PV module

Photovoltaic modules are composed of several PV cells when irradiated generates electric current. This is, usually modeled, as shown in Fig. 2, by a source current I_{ph} , highly dependent on insulation and cell temperature, and a diode representing the intrinsic $P-N$ junction characteristic. Using Kirchoff's law for the adopted one diode equivalent electric circuit model of Fig. 2, the nonlinear I-V characteristics of the PV module can be given by [4]:

$$I = I_{ph} - I_d - I_{sh} \quad (1)$$

$$I = I_{ph} - I_o \left(e^{\frac{q(V+IR_s)}{AKT}} - 1 \right) - \frac{(V + IR_s)}{R_{sh}} \quad (2)$$

Where I and V are the output current and output voltage of the PV module, and:

TABLE II: GPV PARAMETERS

I _{ph} :	The current source of the PV array
I _o :	The reverse saturation current
R _{sh} :	The equivalent parallel resistance
R _s :	The equivalent series resistance
q:	Electronic charge
k:	Boltzmann's constant (1.38×10 ⁻²³ J / °K)
T:	Temperature at cell surface (°K)
A:	Ideality factor of the cell (A=1~5)

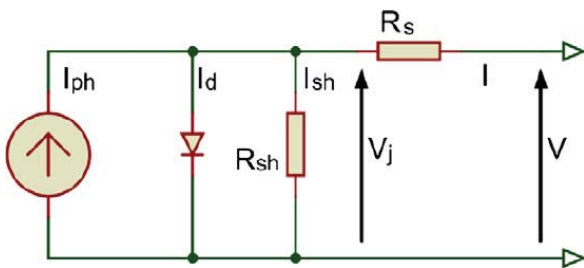

Fig. 2. Equivalent circuit of the single diode model

Arranging several PV cells in series-parallel constitute a photovoltaic generator (GPV) with a nonlinear current-voltage (I-V) characteristic and a maximum power point (MPP) highly

dependent on atmospheric conditions, namely ambient temperature and irradiation levels as illustrated in Fig. 2.

B. DC-DC boost converter model

Generally, in such GPV systems, maximum power transfer happens if the internal resistance of the system matches the load impedance. This is usually achieved by finely tuning the duty cycle of a DC-DC power converter inserted between the load and the PV system [7]. In this work a boost dc-dc converter, illustrated in Fig. 3, is used. The output voltage V_o of the GPV system can be expressed by [8, 9]:

$$V_i = (1-D)V_o \quad (3)$$

Where V_i and D represent the input voltage and the duty cycle of the switching period respectively.

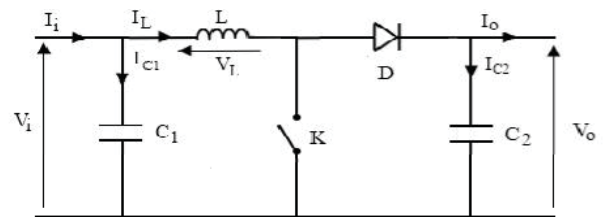

Fig. 3. DC-DC Boost converter

Fine adjustment of the duty cycle leads to impedance matching between the load R_L and the PV source. Alternatively, optimal matching is attained when I_{pv} and V_{pv} of the GPV equates respectively I_{opt} and V_{opt} corresponding to optimal impedance R_{opt} , in terms of R_L and the duty cycle D described by [7]:

$$R_{opt} = \frac{V_{opt}}{I_{opt}} = (1-D^2) \frac{V_o}{I_o} = (1-D^2) R_L \quad (4)$$

C. Artificial neural network based MPPT

ANNs are known to be very efficient to treat complicated problems presenting nonlinearities [4, 6]. An artificial neural network represents a system imitating the biological neural network functions. It is principally composed of connected neurons similar to brain cells. Generally, ANN are made up of one input layer, one output layer and one or several hidden layers. Each layer is completely linked to adjacent layers by interconnection weights w_{ij} as depicted in Fig. 4 [6]. The neural network should be appropriately trained in order to accomplish the intended task accurately. The inputs could be the PV module parameters such as V_{oc} and I_{sc} , the irradiance and temperature, or any arrangement of these. The output is generally the duty cycle used as input to the converter to operate around the MPP point.

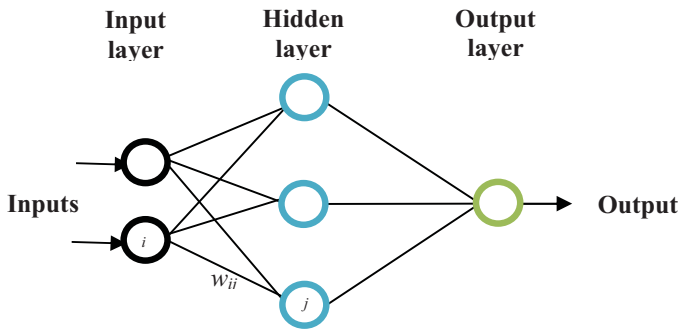

Fig. 4. Example of a neural network

In this work, the proposed feedforward NN structure shown in Fig.5, is made up of two inputs, namely the insulation G and the temperature T , two hidden layers composed of 10 and 8 neurons respectively, and one output neuron representing the duty cycle D . Both input and hidden layers have *tansig* as activation function, while the output uses a *logsig* activation function. The training procedure is accomplished using Levenberg-Marquardt backpropagation optimization. Using the one-diode model for the Kyocera200G PV module, the training data set consists of 270 different $I-V$ curves for values of irradiation varying from $200 W/m^2$ to $1000 W/m^2$ and temperature changing in the range of $[15 \ 45^\circ C]$. From each $I-V$ curve, values of \hat{V}_{mp} and \hat{I}_{mp} , representing respectively the voltage and the current at MPP, are estimated to determine the optimum impedance $R_{opt} = \hat{V}_{mp} / \hat{I}_{mp}$. Using equation (4), the corresponding duty cycle is given by:

$$D = 1 - \sqrt{\frac{R_{opt}}{R_L}} \quad (5)$$

Hence a dataset composed of 270 different values of G , T and D is obtained, where 70% of the values are used for training and the rest is used for testing the neural network.

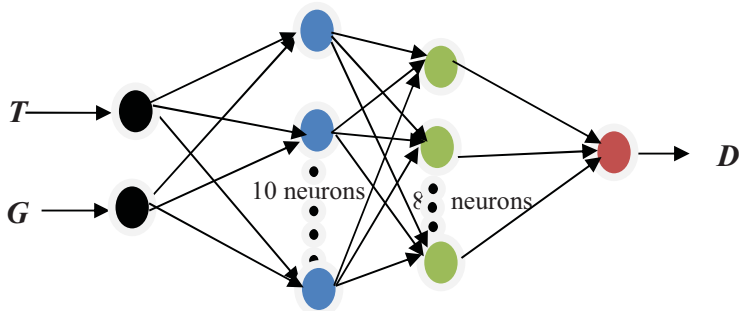

Fig. 5. proposed feedforward NN structure

To assess the performance of the proposed ANN-based scheme with respect to the well known P&O technique, two error index criteria evaluating the difference between the input and the output powers of the PV system [10]:

-The Root mean square error (RMSE):

$$RMSE = \sqrt{\frac{\sum_{i=1}^N (P_{in}^i - P_{out}^i)^2}{N}} \quad (6)$$

-The mean absolute percentage error (MAPE):

$$MAPE = \frac{100\%}{N} \sum_{i=1}^N \left| \frac{P_{in} - \hat{P}_{out}}{P_{in}} \right| \quad (7)$$

Where: P_{in} is input power and P_{out} is output power.

III. SIMULATION RESULTS AND ANALYSIS

This article examines the improvement of the performance of a photovoltaic system using the ANN Maximum Power Point (ANN-MPPT) technique. In order to evaluate the effectiveness of the considered scheme, a comparative study is carried out with the perturb and observe (P&O) MPPT at two different irradiation profiles: slow and fast variation changes. Both MPPT techniques were used as a GPV MPPT controller. The ANN-based MPPT block requires irradiation and temperature to estimate the duty cycle D to determine the Maximum power point (MPPT). The two methods are compared in terms of tracking accuracy and ripples using the RMSE and MAPE error criteria.

Figs 6-9 show the irradiation profiles (Figs. (a)), the input power (Figs. (b)), the output power (Figs. (c)), and the duty cycle (Figs. (d)). Both techniques track correctly the MPPT point according to solar irradiation. From Fig. 6(c) and Fig. 7(c), it can be noticed that the ANN-based technique, exhibiting negligible ripples, is more efficient than the P&O approach. As far as the time response is concerned, the obtained results confirm that the ANN-MPPT method surpasses the P&O system, especially in fast irradiation changes, as illustrated by Fig. 8(c) and Fig. 9(c). To put it clear, the values of the RMSE and the MAPE of the input and output powers are computed and reported in table III. The obtained results, shown in Figs. 10-11, prove clearly the effectiveness of the proposed method compared to the P&O technique.

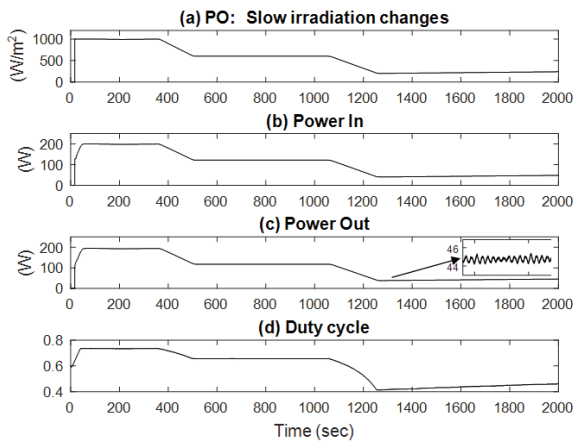

Fig. 6. P&O technique performance under slow irradiation changes, (a) irradiation profile, (b) input power, (c) output power, (d) duty cycle

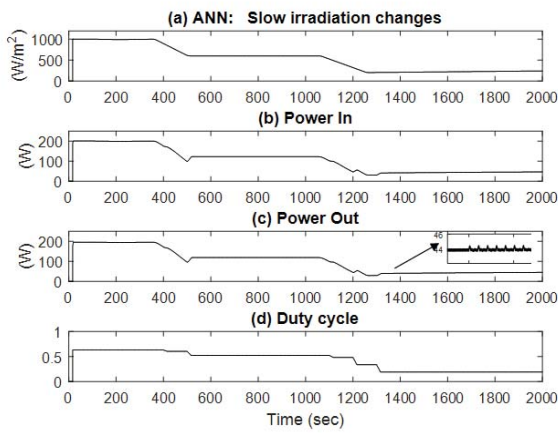

Fig. 7. ANN-MPPT technique performance under slow irradiation changes, (a) irradiation profile, (b) input power, (c) output power, (d) duty cycle

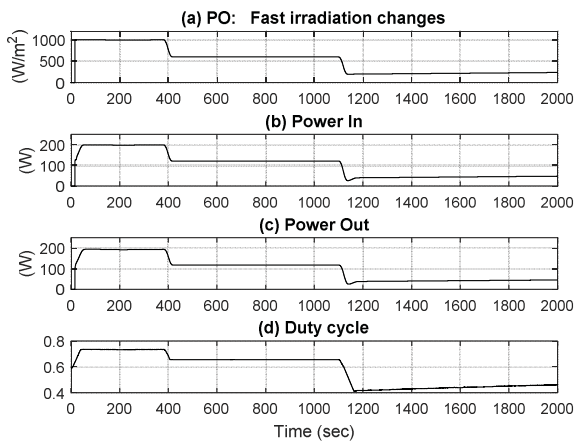

Fig. 8. P&O technique performance under fast irradiation changes, (a) irradiation profile, (b) input power, (c) output power, (d) duty cycle

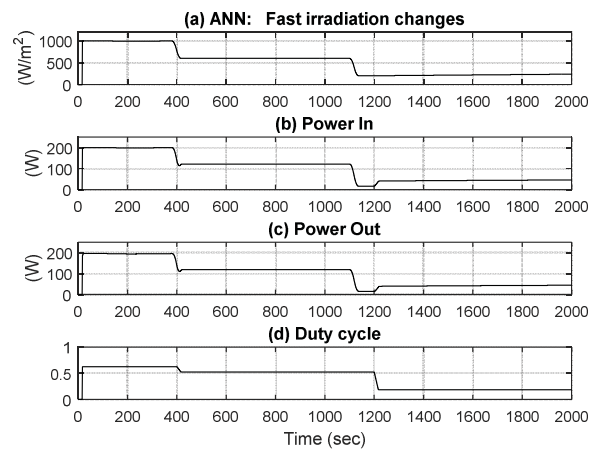

Fig. 9. ANN-MPPT technique performance under fast irradiation changes, (a) irradiation profile, (b) input power, (c) output power, (d) duty cycle

TABLE III RMSE AND THE MAPE OF THE INPUT AND OUTPUT POWERS

	Slow irradiation changes		Fast irradiation changes	
	RMSE	MAPE (%)	RMSE	MAPE (%)
P&O	3.7734	3.4600	3.9119	3.8300
ANN	3.0404	2.8700	3.0225	3.0000

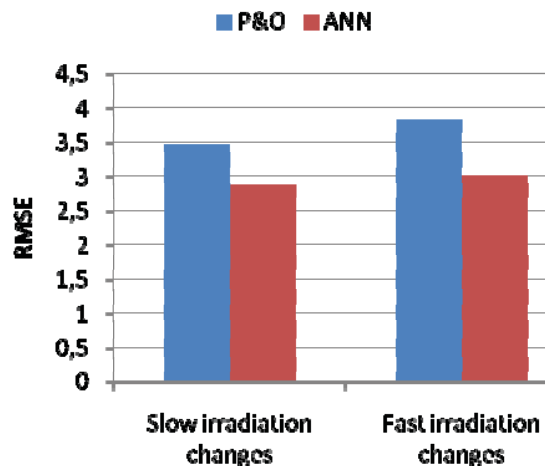

Fig. 10. RMSE histogram of the input and output powers

IV. CONCLUSIONS

In this paper, a MPPT technique based on ANN is examined. The trained NN outputs a tuned duty cycle, applied to a boost converter that ensures the impedance matching between the GPV and the load to guarantee a maximum power transfer. To evaluate the efficiency of the considered MPPT scheme, a comparison against the classical P&O MPPT method is conducted in terms of dynamic response, ripples, and

tracking accuracy. Using Matlab/Simulink, both techniques show good tracking performance. Yet, the ANN-MPPT approach presents negligible oscillations around the MPP which makes it more efficient.

dataset,” *Energy Conversion and Management* vol. 148, pp. 1070–1081, 2017.

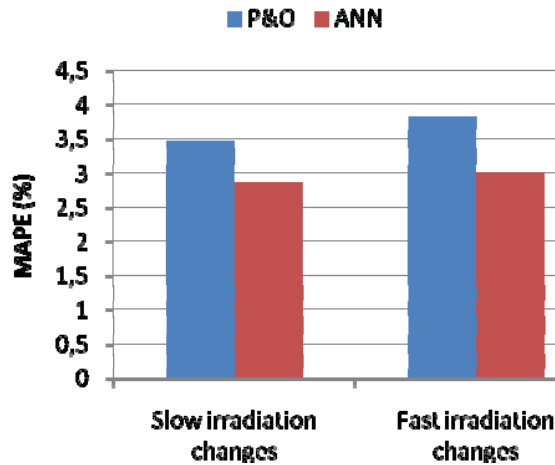

Fig. 11. MAPE histogram of the input and output powers

REFERENCES

- [1] H. Rezk and E. Hasaneen, “A new MATLAB/Simulink model of triple-junction solar cell and MPPT based on artificial neural networks for photovoltaic energy systems,” *Ain Shams Engineering Journal* vol. 6, pp. 873–881, 2015.
- [2] A. Safari and S. Mekhilef, “Simulation and Hardware Implementation of Incremental Conductance MPPT With Direct Control Method Using Cuk Converter,” *IEEE Trans. Indus. Electron* vol. 58, no. 4, pp. 1154–1161, 2011.
- [3] N. Femia, G. Petrone, G. Spagnuolo, and M. Vitelli, “Optimization of Perturb and Observe Maximum Power Point Tracking Method,” *IEEE Trans. Aerospace Electro systems*, vol. 20, no. 4, pp. 963–973, 2005.
- [4] A. R. Reisi, M.H. Moradib and S. Jamasb, “Classification and comparison of maximum power point tracking techniques for photovoltaic system: A review,” *Renewable and Sustainable Energy Reviews* vol. 19, pp. 433–443, 2013.
- [5] R. Garraoui, M. Ben Hamed and L. Sbita, “MPPT controller for a photovoltaic power system based on fuzzy logic,” 10th International Multi-Conference on Systems, Signals & Devices (SSD), pp.1-6, 2013.
- [6] N. Karamia, N. Moubayedb and R. Outbibe, “General review and classification of different MPPT Techniques,” *Renewable and Sustainable Energy Reviews*, vol. 68, pp. 1–18, 2017.
- [7] M. E. Başoğlu and B. Çakır, “Comparisons of MPPT performances of isolated and non-isolated DC–DC converters by using a new approach,” *Renewable and Sustainable Energy Reviews*, vol. 60, pp. 1100–1113, 2016.
- [8] L. Bouselham, M. Hajji, B. Hajji and H. Bouali, “A new MPPT-based ANN for photovoltaic system under partial shading conditions,” 8th International Conference on Sustainability in Energy and Buildings, SEB-16, Turin, ITALY, 11-13 September 2016.
- [9] M. Farhat, O. Barambones and L. Sbita, “Efficiency optimization of a DSP-based standalone PV system using a stable single input fuzzy logic controller,” *Renewable and Sustainable Energy Reviews*, vol. 49, pp. 907–920, 2015.
- [10] H. A. Kazem and J. H. Yousif, “Comparison of prediction methods of photovoltaic power system production using a measured